



E9\*65R00/10\*6675\*00

Página / Page 1/2

COMUNICACIÓN / COMMUNICATION:

Concerniente a <sup>(1)</sup>: LA CONCESIÓN DE HOMOLOGACIÓN  
~~LA EXTENSIÓN DE HOMOLOGACIÓN~~  
~~LA DENEGACIÓN DE HOMOLOGACIÓN~~  
~~LA RETIRADA DE HOMOLOGACIÓN~~  
~~EL CESE DEFINITIVO DE PRODUCCIÓN~~

Concerning <sup>(1)</sup>: ~~APPROVAL GRANTED~~  
~~APPROVAL EXTENDED~~  
~~APPROVAL REFUSED~~  
~~APPROVAL WITHDRAWN~~  
~~PRODUCTION DEFINITELY DISCONTINUED~~

de un tipo de luz especial de aviso para automóviles en aplicación del Reglamento N° 65.  
of a type of special warning lamp for motor vehicles, pursuant to Regulation No.65.

N° de homologación / Approval No.: E9\*65R00/10\*6675\*00

Extensión N° / Extension No.: ---

- Luz especial de aviso / ~~rotativa / luz estacionaria intermitente / luz direccional intermitente / barra completa / media barra / azul / amarillo auto / rojo~~ <sup>(1)</sup> / ~~Special warning lamp / rotating / stationary flashing lamp / directional flashing lamp / complete bar / half bar / blue / amber / red~~ <sup>(1)</sup>
- Luz especial de aviso con ~~un~~ / dos nivel(es) de intensidad <sup>(1)</sup> / ~~Special warning lamp has one~~ / two level(s) of intensity <sup>(1)</sup>  
  
Luz especial de aviso formada por --- unidades separadas / ~~Special warning lamp consists of~~ --- separate units
- Para las luces especiales de aviso con dos niveles de intensidad, sistema empleado para obtener intensidad reforzada de día / ~~For special warning lamps having two levels of intensity, indicate the system used to obtain increased intensity at daytime: ---~~
- Fuente de luz utilizada / Used light source:
  - categoría de lámpara de incandescencia / category of filament lamp: ~~sí / yes~~ - no / no <sup>(1)</sup>
  - lámpara de descarga de gas / gas discharge light source: ~~sí / yes~~ - no / no <sup>(1)</sup>
  - LED: ~~sí / yes~~ - no / no <sup>(1)</sup>
  - Módulo de fuente de luz / Light source module: ~~sí / yes~~ - no / no <sup>(1)</sup>  
Código específico de identificación del módulo de fuente de luz / Light source module specific identification code: ---
- Tensión nominal de la luz especial de aviso / Rated voltage of special warning lamp: 12V/24V
- Marca o denominación comercial / Trade name or mark: BORY AUTO LIGHT

Tipo / Type: BR0400622(B)

(1) Táchese lo que no proceda / Strike out what does not apply





E9\*65R00/10\*6675\*00

Página / Page 2/2

7. Nombre y dirección del fabricante / *Manufacturer's name and address:*  
Guangzhou Bory Auto Light Co., Ltd.  
4/F, Building 8, No.2 Ke'er Road(Self compiled), Dongyong Town, Nansha District, Guangzhou, Guangdong  
511443, China.  
Nota / *Note:* Este dispositivo puede ser fabricado en cualquiera de las Plantas de Fabricación que consten  
declaradas en el Anexo I del Certificado Conformidad Producción en vigor emitido por la UCA. / *This device  
may be manufactured in any of the Manufacturing Plants declared in Annex I of the Conformity Production  
Certificate in force issued by the UCA.*
8. En su caso, nombre y dirección del representante del fabricante / *If applicable, name and address of  
manufacturer's representative:---*
9. Dispositivo presentado a homologación el / *Submitted for approval on:* 30/07/2021
10. Servicio técnico encargado de los ensayos de homologación / *Technical service responsible for conducting  
approval test:* IDIADA
11. Fecha del informe emitido por dicho servicio / *Date of report issued by that service:* 10/08/2021
12. Número del informe emitido por dicho servicio / *Number of report issued by that service:* CN21080122
13. Se concede/~~deniega~~/~~extiende~~/~~retira~~ la homologación <sup>(1)</sup> / *Approval granted/~~refused~~/~~extended~~/~~withdrawn~~* <sup>(1)</sup>
14. Motivos de la extensión (en su caso) / *Reason(s) of extension (if applicable): ---*
15. Lugar / *Place:* Madrid
16. Fecha / *Date:* Ver firma electrónica / *See electronic signature*
17. Firma / *Signature:*  
  
EL SUBDIRECTOR GENERAL DE CALIDAD Y SEGURIDAD INDUSTRIAL  
Resolución P.D. del DIRECTOR GENERAL DE INDUSTRIA Y DE LA PYME de 25-10-2012
18. Se adjunta la lista de apartados que constituyen el expediente de homologación depositado en el servicio  
administrativo que ha concedido la homologación y que pueden ser obtenidos a petición. / *The list of documents  
deposited with the Administrative Service which has granted approval is annexed to this communication and  
may be obtained on request.*
  - Informe del ensayo / *Test report*
  - Documentación suministrada por el fabricante / *Documentation supplied by the manufacturer*

(1) Táchese lo que no proceda / *Strike out what does not apply*



**INFORME N° / REPORT No. CN21080122****RELATIVO A LA HOMOLOGACIÓN DE LUCES ESPECIALES DE AVISO PARA AUTOMÓVILES  
SEGÚN EL REGLAMENTO UN 65.00 / CONCERNING THE APPROVAL OF SPECIAL WARNING LIGHTS  
FOR POWER-DRIVEN VEHICLES ACCORDING TO REGULATION UN 65.00**

Nombre y dirección del fabricante /  
*Manufacturer's name and address* : Guangzhou Bory Auto Light Co., Ltd.  
4/F, Building 8, No.2 Ke'er Road(Self compiled), Dongyong  
Town, Nansha District, Guangzhou, Guangdong 511443,  
China.

Marca comercial / *Trade mark* : BORY AUTO LIGHT

Tipo / *Type* : BR0400622(B)

Lugar y fecha de emisión del informe /  
*Place and date of test report issue* : L'Albornar, Santa Oliva (Tarragona)  
10/08/2021

**CONCLUSIONES / CONCLUSIONS:** El dispositivo presentado **CUMPLE** las prescripciones relativas a la homologación de luces especiales de aviso para automóviles en aplicación del Reglamento N° 65.00 UN, según se detalla en el anexo que se adjunta a este informe / *This device FULFILLS the prescriptions with regard to the approval of special warning lights in application of Regulation No.65.00 UN, as detailed in the annex to this report.*

Realizado por / *Performed by:*Joan Fonts Sala  
INGENIERO DE ENSAYOS  
*TEST ENGINEER*V. B°. / *Revised by:*Josep Masip Gomez  
JEFE DE DEPARTAMENTO  
*DEPARTMENT MANAGER*

\* LOS RESULTADOS PRESENTADOS SE REFIEREN ÚNICAMENTE A LA MUESTRA ENSAYADA.  
*THE PRESENTED RESULTS REFER ONLY TO THE TESTED SAMPLE*

\* QUEDA TERMINANTEMENTE PROHIBIDA LA REPRODUCCIÓN PARCIAL DE ESTE INFORME SIN PERMISO EXPRESO DE IDIADA.  
*THE PARTIAL REPRODUCTION OF THIS REPORT WITHOUT THE PERMISSION OF IDIADA IS COMPLETELY FORBIDDEN*



**ANEXO AL INFORME  
ANNEX TO THE REPORT**

**RELATIVO A LA HOMOLOGACIÓN DE LUCES ESPECIALES DE AVISO PARA AUTOMÓVILES  
SEGÚN EL REGLAMENTO UN 65.00 / CONCERNING THE APPROVAL OF SPECIAL WARNING LIGHTS  
FOR POWER-DRIVEN VEHICLES ACCORDING TO REGULATION UN 65.00**

Nombre y dirección del fabricante / <i>Manufacturer's name and address</i>	:	Guangzhou Bory Auto Light Co., Ltd. 4/F, Building 8, No.2 Ke'er Road(Self compiled), Dongyong Town, Nansha District, Guangzhou, Guangdong 511443, China.
Marca comercial / <i>Trade mark</i>	:	BORY AUTO LIGHT
Tipo / <i>Type</i>	:	BR0400622(B)
Variantes / <i>Variants</i>	:	--
Identificación de las muestras / <i>Sample identification</i>	:	CN21080122
Luz especial de aviso / <i>Special warning lamp *</i>	:	<del>Rotativa / Rotating</del> <del>Luz estacionaria intermitente / Stationary flashing lamp</del> <del>Luz direccional intermitente / Directional flashing lamp</del> <del>Barra completa / Complete bar</del> <del>Media barra / Half bar</del>
Categoría / <i>Category</i>	:	X
Color / <i>Colour</i>	:	Azul / Blue
Clase / <i>Class *</i>	:	± / 2
Patrones de destello / <i>Flash patterns</i>	:	Un pulso por Flash / One pulse per flash
Fuente luminosa / <i>Light source</i>	:	LED
Módulo de fuente luminosa / <i>Light source module *</i>	:	<del>Si / Yes</del> — No / No
Código específico de identificación del módulo de fuente luminosa / <i>Light source module specific identification code:</i>	:	----
Tensión nominal / <i>Rated voltage *</i>	:	12 / 24 V

\* Táchese lo que no proceda / *Strike out what does not apply*

\* LOS RESULTADOS PRESENTADOS SE REFIEREN ÚNICAMENTE A LA MUESTRA ENSAYADA.  
*THE PRESENTED RESULTS REFER ONLY TO THE TESTED SAMPLE.*

\* QUEDA TERMINANTEMENTE PROHIBIDA LA REPRODUCCIÓN PARCIAL DE ESTE INFORME SIN PERMISO EXPRESO DE IDIADA.  
*THE PARTIAL REPRODUCTION OF THIS REPORT WITHOUT THE PERMISSION OF IDIADA IS COMPLETELY FORBIDDEN.*

\* EL LABORATORIO HA CALCULADO LA INCERTIDUMBRE DE MEDIDA ASOCIADA A LOS RESULTADOS.  
*MEASUREMENT UNCERTAINTY OF THE RESULTS HAS BEEN CALCULATED BY THE LABORATORY.*



**MARCAJE / MARKING**

<p>Marcaje / Marking</p>	<p><b>CORRECTO / CORRECT</b></p>
------------------------------	--------------------------------------

**ESPECIFICACIONES GENERALES / GENERAL SPECIFICATIONS**

<p>Resistencia a las vibraciones / <i>Vibration endurance</i></p>	<p><b>CORRECTO / CORRECT</b></p>
<p>No hay posibilidad de desajuste una vez la luz ha sido instalada correctamente en el vehículo. / <i>No maladjustment is possible after the light has been mounted correctly on the vehicle.</i></p>	<p><b>CORRECTO / CORRECT</b></p>
<p>Tiene que conectarse directamente a la red de voltaje suministrado por el coche por conexión directa o conectores habituales (por ejemplo, el enchufe del encendedor). / <i>Shall be powered directly from the voltage supply network of the vehicle by direct connection or usual connectors (e.g. cigarette lighter plug).</i></p>	<p><b>CORRECTO / CORRECT</b></p>
<p>Cuando se use una fuente luminosa no reemplazable, ésta debe estar fijada de modo permanente sobre el dispositivo. / <i>When a non-replaceable light source is used it shall be permanently fixed to the special warning lamp.</i></p>	<p><b>CORRECTO / CORRECT</b></p>
<p>En el caso que el sistema use una fuente de alimentación especial, o una fuente de alimentación dedicada, o un mecanismo de control de la fuente luminosa forma parte de la luz especial de aviso. / <i>In the case of a system that uses a special power supply, or a dedicated power supply, or light source control gear is part of special warning lamp.</i></p>	<p><b>NO APLICABLE / NOT APPLICABLE</b></p>
<p>Frecuencia <math>f</math>, tiempo de encendido <math>t_H</math> y tiempo de apagado <math>t_D</math> medidos a temperatura ambiente de <math>+23^{\circ}\text{C} \pm 5^{\circ}\text{C}</math> y con tensiones entre el 90% y el 115% de la tensión nominal. / <i>Frequency <math>f</math>, "on" time <math>t_H</math> and "off" time <math>t_D</math> measured at an ambient temperature of <math>+23^{\circ}\text{C} \pm 5^{\circ}\text{C}</math> and with voltages between 90% and 115% of the rated voltage.</i></p>	<p><b>CORRECTO / CORRECT</b></p>
<p>El encendido y el funcionamiento correcto de la luz especial de aviso deberán estar asegurados a temperaturas entre <math>-20^{\circ}\text{C}</math> y <math>+50^{\circ}\text{C}</math>. La frecuencia está comprendida entre 2 y 4 Hz un minuto después de aplicar una tensión igual al 90% de la tensión nominal. / <i>Starting and correct functioning of the special warning lamp remains assured at temperature between <math>-20^{\circ}\text{C}</math> and <math>+50^{\circ}\text{C}</math>. Frequency remains between 2 and 4 Hz one minute after a voltage equal to 90 % of the rated voltage is applied.</i></p>	<p><b>CORRECTO / CORRECT</b></p>
<p>El volumen de agua acumulado después del ensayo no excede <math>2\text{ cm}^3</math>. / <i>Accumulated volume of water after the test does not exceed <math>2\text{ cm}^3</math>.</i></p>	<p><b>CORRECTO / CORRECT</b></p>
<p>Una luz especial de aviso rotativa o intermitente de categoría T puede emitir luz de varios colores. En este caso se deberán cumplir todos los requisitos para cada color por separado sobre el rango angular completo especificado. La activación de más de un color al mismo tiempo está prohibida. / <i>A rotating or flashing special warning lamp device of Category T may emit light of several colours. In this case all the requirements shall be met for each colour separately over the full angular range specified. The activation of more than one colour at the same time shall be prohibited.</i></p>	<p><b>NO APLICABLE / NOT APPLICABLE</b></p>
<p>En el caso de luces especiales de aviso homologadas en virtud del presente Reglamento, no será posible para el usuario activar grupos de varios flashes (patrones de destello), que no se ajusten a los requisitos establecidos en el párrafo 6 del Anexo 5. / <i>In the case of special warning lamps approved under this Regulation, it shall be not possible for the user to activate groups of several flashes (flash patterns), which do not conform to the requirements in paragraph 6 of Annex 5.</i></p>	<p><b>CORRECTO / CORRECT</b></p>

Validate this report with the security code «961YJHTJ» at: <https://extranet.idiada.com/hom-cve>  
Verifique el informe con código de seguridad «961YJHTJ» en: <https://extranet.idiada.com/hom-cve>

**IDIADA** CN21080122

\* LOS RESULTADOS PRESENTADOS SE REFIEREN ÚNICAMENTE A LA MUESTRA ENSAYADA.  
*THE PRESENTED RESULTS REFER ONLY TO THE TESTED SAMPLE.*

\* QUEDA TERMINANTEMENTE PROHIBIDA LA REPRODUCCIÓN PARCIAL DE ESTE INFORME SIN PERMISO EXPRESO DE IDIADA.  
*THE PARTIAL REPRODUCTION OF THIS REPORT WITHOUT THE PERMISSION OF IDIADA IS COMPLETELY FORBIDDEN.*

\* EL LABORATORIO HA CALCULADO LA INCERTIDUMBRE DE MEDIDA ASOCIADA A LOS RESULTADOS.  
*MEASUREMENT UNCERTAINTY OF THE RESULTS HAS BEEN CALCULATED BY THE LABORATORY.*



## MÓDULO DE FUENTE LUMINOSA / LIGHT SOURCE MODULE

Ajuste correcto / <i>Correct fitting</i>	<b>NO APLICABLE / NOT APPLICABLE</b>
Resistente a la manipulación / <i>Tamperproof</i>	<b>NO APLICABLE / NOT APPLICABLE</b>

**ESPECIFICACIONES COLORIMÉTRICAS / COLORIMETRIC SPECIFICATIONS**

## ZONA AZUL / BLUE ZONE:

- Límite hacia el verde / *Limit towards the green*:  $y \leq 0.065 + 0.805x$
- Límite hacia el blanco / *Limit towards the white*:  $y \leq 0.400 - x$
- Límite hacia el púrpura / *Limit towards the purple*:  $y \geq 1.667x - 0.222$

Coordenadas cromáticas / <i>Chromatic co-ordinates</i> (eje de referencia / <i>reference axis</i> )	MUESTRA A / <i>SAMPLE A</i>		MUESTRA B / <i>SAMPLE B</i>	
	Lente 1 / <i>Lens 1</i>	Lente 2 / <i>Lens 2</i>	Lente 1 / <i>Lens 1</i>	Lente 2 / <i>Lens 2</i>
<b>x</b>	<b>0.1163</b>	---	<b>0.1162</b>	---
<b>y</b>	<b>0.1496</b>	---	<b>0.1497</b>	---
<b>z</b>	<b>0.7341</b>	---	<b>0.7341</b>	---

**ESPECIFICACIONES FOTOMÉTRICAS / PHOTOMETRIC SPECIFICATIONS**

## MEDIDAS DE FRECUENCIA / FREQUENCY MEASUREMENTS

(T = 23°C ± 5°C)

	Frecuencia / <i>Frequency</i> (2 Hz ≤ f ≤ 4 Hz)	
	MUESTRA A / <i>SAMPLE A</i>	MUESTRA B / <i>SAMPLE B</i>
Tensión nominal / <i>Nominal voltage</i>	<b>2.480 Hz</b>	<b>2.480 Hz</b>
90% tensión nominal / <i>90% nominal voltage</i>	<b>2.480 Hz</b>	<b>2.480 Hz</b>
115% tensión nominal / <i>115% nominal voltage</i>	<b>2.480 Hz</b>	<b>2.480 Hz</b>

 MEDIDAS DEL TIEMPO DE ENCENDIDO (t<sub>H</sub>) / "ON" TIME MEASUREMENTS (t<sub>H</sub>)

(T = 23°C ± 5°C)

	Tiempo de encendido (t <sub>H</sub> ) ≤ 0.4 / f / "ON" time (t <sub>H</sub> ) ≤ 0.4 / f	
	MUESTRA A / <i>SAMPLE A</i>	MUESTRA B / <i>SAMPLE B</i>
Tensión Nominal / <i>Rated voltage</i>	t <sub>H</sub> = <b>130.9 ms</b> ≤ 0.4 / f = <b>161.2 ms</b>	t <sub>H</sub> = <b>130.9 ms</b> ≤ 0.4 / f = <b>161.2 ms</b>
90% tensión / <i>90% voltage</i>	t <sub>H</sub> = <b>130.9 ms</b> ≤ 0.4 / f = <b>161.2 ms</b>	t <sub>H</sub> = <b>130.9 ms</b> ≤ 0.4 / f = <b>161.2 ms</b>
115% tensión / <i>115% voltage</i>	t <sub>H</sub> = <b>130.9 ms</b> ≤ 0.4 / f = <b>161.2 ms</b>	t <sub>H</sub> = <b>130.9 ms</b> ≤ 0.4 / f = <b>161.2 ms</b>

 MEDIDAS DEL TIEMPO DE APAGADO (t<sub>D</sub>) / "OFF" TIME MEASUREMENTS (t<sub>D</sub>)

(T = 23°C ± 5°C)

	Tiempo de apagado (t <sub>D</sub> ) ≥ 0.1 s / "OFF" time (t <sub>D</sub> ) ≥ 0.1 s	
	MUESTRA A / <i>SAMPLE A</i>	MUESTRA B / <i>SAMPLE B</i>
Tensión Nominal / <i>Rated voltage</i>	t <sub>D</sub> = <b>272.5 ms</b> ≥ 0.1 s	t <sub>D</sub> = <b>272.5 ms</b> ≥ 0.1 s
90% tensión / <i>90% voltage</i>	t <sub>D</sub> = <b>272.5 ms</b> ≥ 0.1 s	t <sub>D</sub> = <b>272.5 ms</b> ≥ 0.1 s
115% tensión / <i>115% voltage</i>	t <sub>D</sub> = <b>272.5 ms</b> ≥ 0.1 s	t <sub>D</sub> = <b>272.5 ms</b> ≥ 0.1 s

\* LOS RESULTADOS PRESENTADOS SE REFIEREN ÚNICAMENTE A LA MUESTRA ENSAYADA.  
THE PRESENTED RESULTS REFER ONLY TO THE TESTED SAMPLE.

\* QUEDA TERMINANTEMENTE PROHIBIDA LA REPRODUCCIÓN PARCIAL DE ESTE INFORME SIN PERMISO EXPRESO DE IDIADA.  
THE PARTIAL REPRODUCTION OF THIS REPORT WITHOUT THE PERMISSION OF IDIADA IS COMPLETELY FORBIDDEN.

\* EL LABORATORIO HA CALCULADO LA INCERTIDUMBRE DE MEDIDA ASOCIADA A LOS RESULTADOS.  
MEASUREMENT UNCERTAINTY OF THE RESULTS HAS BEEN CALCULATED BY THE LABORATORY.



MEDIDAS DE LA DIFERENCIA DE TIEMPO / TIME DISTANCE MEASUREMENTS ( $\Delta t$ )

Si la luz emitida por una luz especial de aviso está constituida por grupos de varios destellos, la diferencia de tiempo  $\Delta t$  entre los destellos consecutivos debe ser muy corta. / *If the emitted light of a special warning lamp consists of groups of several flashes, the time distance  $\Delta t$  between the immediately following flashes must be very short.*

$\Delta t$ (distancia de pico a pico / peak to peak distance) = -- ms
---

- A) Si  $\Delta t \leq 40\text{ms}$  las pulsaciones intermedias son consideradas como un destello / *If  $\Delta t \leq 40\text{ms}$  the pulses in between are evaluated as one flash*
- B) Si  $\Delta t > 40\text{ms}$  se considera válido el destello de intensidad efectiva más fuerte / *If  $\Delta t > 40\text{ms}$  the flash with the highest effective intensity is valid:*

$I_H$ : intensidad efectiva máxima del pico más fuerte / <i>maximum effective intensity of the highest peak</i>	$I_H / I_L = \text{---}$ <b>NO APLICABLE /</b> <b>NOT APPLICABLE</b>
$I_L$ : intensidad efectiva máxima del pico más débil / <i>maximum effective intensity of the lowest peak</i>	

B1)  $I_H / I_L > 10$

$$\Delta t = \text{--- ms} < \frac{1}{3f} = \text{--- ms}$$

B2)  $1 < I_H / I_L < 10$

$$\Delta t = \text{--- ms} < \frac{1}{f(5.5 - 0.25 \frac{I_H}{I_L})} = \text{--- ms}$$

Validate this report with the security code «961YJHTJ» at: <https://extranet.idiada.com/hom-cve>  
 Verifique el informe con código de seguridad «961YJHTJ» en: <https://extranet.idiada.com/hom-cve>

CN21080122



\* LOS RESULTADOS PRESENTADOS SE REFIEREN ÚNICAMENTE A LA MUESTRA ENSAYADA.  
*THE PRESENTED RESULTS REFER ONLY TO THE TESTED SAMPLE.*

\* QUEDA TERMINANTEMENTE PROHIBIDA LA REPRODUCCIÓN PARCIAL DE ESTE INFORME SIN PERMISO EXPRESO DE IDIADA.  
*THE PARTIAL REPRODUCTION OF THIS REPORT WITHOUT THE PERMISSION OF IDIADA IS COMPLETELY FORBIDDEN.*

\* EL LABORATORIO HA CALCULADO LA INCERTIDUMBRE DE MEDIDA ASOCIADA A LOS RESULTADOS.  
*MEASUREMENT UNCERTAINTY OF THE RESULTS HAS BEEN CALCULATED BY THE LABORATORY.*



MEDIDA DE LA INTENSIDAD LUMINOSA EFECTIVA / *EFFECTIVE LUMINOUS INTENSITY MEASUREMENT*

DE DÍA / BY DAY

1. Intensidades luminosas efectivas medidas después de un minuto de encendido. Unidad de medida:  $cd_{eff}$ . / *Effective luminous intensities measured after one minute of operation. Measurement unit:  $cd_{eff}$ .*

MUESTRA A / *SAMPLE A*

H→ V↓	90°	45°	30°	20°	10°	0°	10°	20°	30°	45°	90°	
<b>min</b> <b>8°</b> <b>max</b>					100 <b>206.0</b> 1500		100 <b>203.1</b> 1500					
<b>min</b> <b>6°</b> <b>max</b>				100 <b>220.8</b> 1500		150 <b>222.8</b> 1500		100 <b>216.7</b> 1500				
<b>min</b> <b>4°</b> <b>max</b>	40 1000	40 1000	40 <b>198.8</b> 1000		200 <b>287.4</b> 3000		200 <b>281.7</b> 3000		40 <b>179.4</b> 1000	40 1000	40 1000	
<b>min</b> <b>0°</b> <b>max</b>	100 1000	100 1000	100 <b>210.7</b> 1000	150 <b>290.9</b> 1500		200 <b>319.9</b> 3000		150 <b>293.7</b> 1500	100 <b>193.2</b> 1000	100 1000	100 1000	
<b>min</b> <b>4°</b> <b>max</b>	40 1000	40 1000	40 <b>163.9</b> 1000		200 <b>251.4</b> 3000		200 <b>260.4</b> 3000		40 <b>159.1</b> 1000	40 1000	40 1000	
<b>min</b> <b>6°</b> <b>max</b>				100 <b>164.6</b> 1500		150 <b>196.8</b> 1500		100 <b>179.6</b> 1500				
<b>min</b> <b>8°</b> <b>max</b>					100 <b>133.6</b> 1500		100 <b>148.7</b> 1500					
	WIDE ANGLE EFFECT			NARROW ANGLE EFFECT						WIDE ANGLE EFFECT		

\* LOS RESULTADOS PRESENTADOS SE REFIEREN ÚNICAMENTE A LA MUESTRA ENSAYADA.

*THE PRESENTED RESULTS REFER ONLY TO THE TESTED SAMPLE.*

\* QUEDA TERMINANTEMENTE PROHIBIDA LA REPRODUCCIÓN PARCIAL DE ESTE INFORME SIN PERMISO EXPRESO DE IDIADA.

*THE PARTIAL REPRODUCTION OF THIS REPORT WITHOUT THE PERMISSION OF IDIADA IS COMPLETELY FORBIDDEN.*

\* EL LABORATORIO HA CALCULADO LA INCERTIDUMBRE DE MEDIDA ASOCIADA A LOS RESULTADOS.

*MEASUREMENT UNCERTAINTY OF THE RESULTS HAS BEEN CALCULATED BY THE LABORATORY.*





MUESTRA B / SAMPLE B

H→ V↓	90°	45°	30°	20°	10°	0°	10°	20°	30°	45°	90°	
<b>min</b> 8° <b>max</b>					100 <b>210.3</b> 1500		100 <b>207.3</b> 1500					
<b>min</b> 6° <b>max</b>				100 <b>225.5</b> 1500		150 <b>227.9</b> 1500		100 <b>222.5</b> 1500				
<b>min</b> 4° <b>max</b>	40 1000	40 1000	40 <b>202.7</b> 1000		200 <b>292.9</b> 3000		200 <b>286.3</b> 3000		40 1000	40 1000	40 1000	
<b>min</b> 0° <b>max</b>	100 1000	100 1000	100 <b>214.9</b> 1000	150 <b>297.1</b> 1500		200 <b>325.7</b> 3000		150 <b>299.1</b> 1500	100 1000	100 1000	100 1000	
<b>min</b> 4° <b>max</b>	40 1000	40 1000	40 <b>167.4</b> 1000		200 <b>255.4</b> 3000		200 <b>263.3</b> 3000		40 1000	40 1000	40 1000	
<b>min</b> 6° <b>max</b>				100 <b>168.5</b> 1500		150 <b>201.5</b> 1500		100 <b>183.1</b> 1500				
<b>min</b> 8° <b>max</b>					100 <b>133.2</b> 1500		100 <b>150.4</b> 1500					
	WIDE ANGLE EFFECT			NARROW ANGLE EFFECT						WIDE ANGLE EFFECT		

Validate this report with the security code «961YJHTJ» at: <https://extranet.idiada.com/hom-cve>  
 Verifique el informe con código de seguridad «961YJHTJ» en: <https://extranet.idiada.com/hom-cve>

CN21080122



\* LOS RESULTADOS PRESENTADOS SE REFIEREN ÚNICAMENTE A LA MUESTRA ENSAYADA.  
 THE PRESENTED RESULTS REFER ONLY TO THE TESTED SAMPLE.  
 \* QUEDA TERMINANTEMENTE PROHIBIDA LA REPRODUCCIÓN PARCIAL DE ESTE INFORME SIN PERMISO EXPRESO DE IDIADA.  
 THE PARTIAL REPRODUCTION OF THIS REPORT WITHOUT THE PERMISSION OF IDIADA IS COMPLETELY FORBIDDEN.  
 \* EL LABORATORIO HA CALCULADO LA INCERTIDUMBRE DE MEDIDA ASOCIADA A LOS RESULTADOS.  
 MEASUREMENT UNCERTAINTY OF THE RESULTS HAS BEEN CALCULATED BY THE LABORATORY.



2. Intensidades luminosas medidas después que la intensidad de la luz de la luz especial de aviso haya alcanzado la estabilidad fotométrica (desviación inferior al  $\pm 5\%$  en los últimos 15 minutos de funcionamiento). Unidad de medida:  $cd_{eff}$ . / *Luminous intensities measured after the light output from the special warning lamp has reached photometric stability (deviation of less than  $\pm 5$  percent in the last 15 minutes of operation). Measurement unit:  $cd_{eff}$ .*

MUESTRA A / SAMPLE A

H→ V↓	90°	45°	30°	20°	10°	0°	10°	20°	30°	45°	90°	
min 8° max					100 205.8 1500		100 202.4 1500					
min 6° max				100 220.6 1500		150 222.4 1500		100 216.4 1500				
min 4° max	40 1000	40 1000	40 197.6 1000		200 286.5 3000		200 279.6 3000		40 178.5 1000	40 1000	40 1000	
min 0° max	100 1000	100 1000	100 210.1 1000	150 290.4 1500		200 318.2 3000		150 292.6 1500	100 192.5 1000	100 1000	100 1000	
min 4° max	40 1000	40 1000	40 163.8 1000		200 250.9 3000		200 258.1 3000		40 157.8 1000	40 1000	40 1000	
min 6° max				100 164.4 1500		150 196.7 1500		100 179.4 1500				
min 8° max					100 131.3 1500		100 147.3 1500					
	WIDE ANGLE EFFECT			NARROW ANGLE EFFECT						WIDE ANGLE EFFECT		

Validate this report with the security code «961YJHTJ» at: <https://extranet.idiada.com/hom-cve>  
 Verifique el informe con código de seguridad «961YJHTJ» en: <https://extranet.idiada.com/hom-cve>

CN21080122



\* LOS RESULTADOS PRESENTADOS SE REFIEREN ÚNICAMENTE A LA MUESTRA ENSAYADA.

*THE PRESENTED RESULTS REFER ONLY TO THE TESTED SAMPLE.*

\* QUEDA TERMINANTEMENTE PROHIBIDA LA REPRODUCCIÓN PARCIAL DE ESTE INFORME SIN PERMISO EXPRESO DE IDIADA.

*THE PARTIAL REPRODUCTION OF THIS REPORT WITHOUT THE PERMISSION OF IDIADA IS COMPLETELY FORBIDDEN.*

\* EL LABORATORIO HA CALCULADO LA INCERTIDUMBRE DE MEDIDA ASOCIADA A LOS RESULTADOS.

*MEASUREMENT UNCERTAINTY OF THE RESULTS HAS BEEN CALCULATED BY THE LABORATORY.*



MUESTRA B / SAMPLE B

H→ V↓	90°	45°	30°	20°	10°	0°	10°	20°	30°	45°	90°	
<b>min</b>					100		100					
<b>8°</b>					<b>209.2</b>		<b>206.2</b>					
<b>max</b>					1500		1500					
<b>min</b>				100		150		100				
<b>6°</b>				<b>224.3</b>		<b>226.7</b>		<b>221.3</b>				
<b>max</b>				1500		1500		1500				
<b>min</b>	40	40	40		200		200		40	40	40	
<b>4°</b>			<b>201.6</b>		<b>291.3</b>		<b>284.8</b>		<b>182.6</b>			
<b>max</b>	1000	1000	1000		3000		3000		1000	1000	1000	
<b>min</b>	100	100	100	150		200		150	100	100	100	
<b>0°</b>			<b>213.8</b>	<b>295.5</b>		<b>324.0</b>		<b>297.5</b>	<b>196.2</b>			
<b>max</b>	1000	1000	1000	1500		3000		1500	1000	1000	1000	
<b>min</b>	40	40	40		200		200		40	40	40	
<b>4°</b>			<b>166.5</b>		<b>254.0</b>		<b>261.9</b>		<b>161.0</b>			
<b>max</b>	1000	1000	1000		3000		3000		1000	1000	1000	
<b>min</b>				100		150		100				
<b>6°</b>				<b>167.6</b>		<b>200.4</b>		<b>182.1</b>				
<b>max</b>				1500		1500		1500				
<b>min</b>					100		100					
<b>8°</b>					<b>132.5</b>		<b>149.6</b>					
<b>max</b>					1500		1500					
	WIDE ANGLE EFFECT			NARROW ANGLE EFFECT						WIDE ANGLE EFFECT		

Validate this report with the security code «961YJHTJ» at: <https://extranet.idiada.com/hom-cve>  
 Verifique el informe con código de seguridad «961YJHTJ» en: <https://extranet.idiada.com/hom-cve>

CN21080122



\* LOS RESULTADOS PRESENTADOS SE REFIEREN ÚNICAMENTE A LA MUESTRA ENSAYADA.  
 THE PRESENTED RESULTS REFER ONLY TO THE TESTED SAMPLE.  
 \* QUEDA TERMINANTEMENTE PROHIBIDA LA REPRODUCCIÓN PARCIAL DE ESTE INFORME SIN PERMISO EXPRESO DE IDIADA.  
 THE PARTIAL REPRODUCTION OF THIS REPORT WITHOUT THE PERMISSION OF IDIADA IS COMPLETELY FORBIDDEN.  
 \* EL LABORATORIO HA CALCULADO LA INCERTIDUMBRE DE MEDIDA ASOCIADA A LOS RESULTADOS.  
 MEASUREMENT UNCERTAINTY OF THE RESULTS HAS BEEN CALCULATED BY THE LABORATORY.



DE NOCHE / BY NIGHT

1. Intensidades luminosas efectivas medidas después de un minuto de encendido / *Effective luminous intensities measured after one minute of operation.*

MUESTRA A / *SAMPLE A*

H→ V↓	90°	45°	30°	20°	10°	0°	10°	20°	30°	45°	90°	
<b>min</b>					50		50					
<b>8°</b>					<b>103.1</b>		<b>108.0</b>					
<b>max</b>					600		600					
<b>min</b>				50		75		50				
<b>6°</b>				<b>114.5</b>		<b>114.3</b>		<b>109.6</b>				
<b>max</b>				600		600		600				
<b>min</b>	20	20	20		100		100		20	20	20	
<b>4°</b>			<b>103.5</b>		<b>143.4</b>		<b>146.9</b>		<b>92.13</b>	300	300	
<b>max</b>	300	300	300		1500		1500		300	300	300	
<b>min</b>	50	50	50	75		100		75	50	50	50	
<b>0°</b>			<b>108.2</b>	<b>148.9</b>		<b>160.1</b>		<b>157.1</b>	<b>97.49</b>	300	300	
<b>max</b>	300	300	300	600		1500		600	300	300	300	
<b>min</b>	20	20	20		100		100		20	20	20	
<b>4°</b>			<b>82.67</b>		<b>127.4</b>		<b>133.4</b>		<b>83.79</b>	300	300	
<b>max</b>	300	300	300		1500		1500		300	300	300	
<b>min</b>				50		75		50				
<b>6°</b>				<b>83.63</b>		<b>98.92</b>		<b>94.24</b>				
<b>max</b>				600		600		600				
<b>min</b>					50		50					
<b>8°</b>					<b>68.70</b>		<b>76.93</b>					
<b>max</b>					600		600					
	WIDE ANGLE EFFECT			NARROW ANGLE EFFECT						WIDE ANGLE EFFECT		

Validate this report with the security code «961YJHTJ» at: <https://extranet.idiada.com/hom-cve>  
 Verifique el informe con código de seguridad «961YJHTJ» en: <https://extranet.idiada.com/hom-cve>

CN21080122



\* LOS RESULTADOS PRESENTADOS SE REFIEREN ÚNICAMENTE A LA MUESTRA ENSAYADA.

*THE PRESENTED RESULTS REFER ONLY TO THE TESTED SAMPLE.*

\* QUEDA TERMINANTEMENTE PROHIBIDA LA REPRODUCCIÓN PARCIAL DE ESTE INFORME SIN PERMISO EXPRESO DE IDIADA.

*THE PARTIAL REPRODUCTION OF THIS REPORT WITHOUT THE PERMISSION OF IDIADA IS COMPLETELY FORBIDDEN.*

\* EL LABORATORIO HA CALCULADO LA INCERTIDUMBRE DE MEDIDA ASOCIADA A LOS RESULTADOS.

*MEASUREMENT UNCERTAINTY OF THE RESULTS HAS BEEN CALCULATED BY THE LABORATORY.*



MUESTRA B / SAMPLE B

H→ V↓	90°	45°	30°	20°	10°	0°	10°	20°	30°	45°	90°	
<b>min</b> <b>8°</b> <b>max</b>					50 <b>105.8</b> 600		50 <b>106.4</b> 600					
<b>min</b> <b>6°</b> <b>max</b>				50 <b>115.0</b> 600		75 <b>119.0</b> 600		50 <b>113.2</b> 600				
<b>min</b> <b>4°</b> <b>max</b>	20 300	20 300	20 <b>107.1</b> 300		100 <b>147.4</b> 1500		100 <b>150.1</b> 1500		20 <b>94.02</b> 300	20 300	20 300	
<b>min</b> <b>0°</b> <b>max</b>	50 300	50 300	50 <b>113.2</b> 300	75 <b>155.0</b> 600		100 <b>171.1</b> 1500		75 <b>163.8</b> 600	50 <b>104.8</b> 300	50 300	50 300	
<b>min</b> <b>4°</b> <b>max</b>	20 300	20 300	20 <b>88.20</b> 300		100 <b>139.5</b> 1500		100 <b>137.5</b> 1500		20 <b>85.69</b> 300	20 300	20 300	
<b>min</b> <b>6°</b> <b>max</b>				50 <b>87.19</b> 600		75 <b>105.75</b> 600		50 <b>95.65</b> 600				
<b>min</b> <b>8°</b> <b>max</b>					50 <b>71.38</b> 600		50 <b>80.01</b> 600					
	WIDE ANGLE EFFECT			NARROW ANGLE EFFECT						WIDE ANGLE EFFECT		

Validate this report with the security code «961YJHTJ» at: <https://extranet.idiada.com/hom-cve>  
 Verifique el informe con código de seguridad «961YJHTJ» en: <https://extranet.idiada.com/hom-cve>

CN21080122



\* LOS RESULTADOS PRESENTADOS SE REFIEREN ÚNICAMENTE A LA MUESTRA ENSAYADA.  
 THE PRESENTED RESULTS REFER ONLY TO THE TESTED SAMPLE.

\* QUEDA TERMINANTEMENTE PROHIBIDA LA REPRODUCCIÓN PARCIAL DE ESTE INFORME SIN PERMISO EXPRESO DE IDIADA.  
 THE PARTIAL REPRODUCTION OF THIS REPORT WITHOUT THE PERMISSION OF IDIADA IS COMPLETELY FORBIDDEN.

\* EL LABORATORIO HA CALCULADO LA INCERTIDUMBRE DE MEDIDA ASOCIADA A LOS RESULTADOS.  
 MEASUREMENT UNCERTAINTY OF THE RESULTS HAS BEEN CALCULATED BY THE LABORATORY.



2. Intensidades luminosas medidas después que la intensidad de la luz de la luz especial de aviso haya alcanzado la estabilidad fotométrica (desviación inferior al  $\pm 5\%$  en los últimos 15 minutos de funcionamiento / *Luminous intensities measured after the light output from the special warning lamp has reached photometric stability (deviation of less than  $\pm 5$  percent in the last 15 minutes of operation).*

MUESTRA A / SAMPLE A

H→ V↓	90°	45°	30°	20°	10°	0°	10°	20°	30°	45°	90°
min 8° max					50 102.9 600		50 99.65 600				
min 6° max				50 110.0 600		75 111.4 600		50 108.7 600			
min 4° max	20 300	20 300	20 100.5 300		100 142.8 1500		100 139.3 1500		20 91.86 300	20 300	20 300
min 0° max	50 300	50 300	50 107.4 300	75 143.7 600		100 157.0 1500		75 144.3 600	50 97.52 300	50 300	50 300
min 4° max	20 300	20 300	20 81.45 300		100 126.1 1500		100 129.0 1500		20 78.53 300	20 300	20 300
min 6° max				50 81.57 600		75 95.83 600		50 88.46 600			
min 8° max					50 66.83 600		50 76.07 600				
	WIDE ANGLE EFFECT		NARROW ANGLE EFFECT						WIDE ANGLE EFFECT		

Validate this report with the security code «961YJHTJ» at: <https://extranet.idiada.com/hom-cve>  
 Verifique el informe con código de seguridad «961YJHTJ» en: <https://extranet.idiada.com/hom-cve>

CN21080122



\* LOS RESULTADOS PRESENTADOS SE REFIEREN ÚNICAMENTE A LA MUESTRA ENSAYADA.  
 THE PRESENTED RESULTS REFER ONLY TO THE TESTED SAMPLE.  
 \* QUEDA TERMINANTEMENTE PROHIBIDA LA REPRODUCCIÓN PARCIAL DE ESTE INFORME SIN PERMISO EXPRESO DE IDIADA.  
 THE PARTIAL REPRODUCTION OF THIS REPORT WITHOUT THE PERMISSION OF IDIADA IS COMPLETELY FORBIDDEN.  
 \* EL LABORATORIO HA CALCULADO LA INCERTIDUMBRE DE MEDIDA ASOCIADA A LOS RESULTADOS.  
 MEASUREMENT UNCERTAINTY OF THE RESULTS HAS BEEN CALCULATED BY THE LABORATORY.



MUESTRA B / SAMPLE B

H→ V↓	90°	45°	30°	20°	10°	0°	10°	20°	30°	45°	90°	
<b>min</b> <b>8°</b> <b>max</b>					50 <b>103.8</b> 600		50 <b>104.3</b> 600					
<b>min</b> <b>6°</b> <b>max</b>				50 <b>112.8</b> 600		75 <b>116.7</b> 600		50 <b>111.0</b> 600				
<b>min</b> <b>4°</b> <b>max</b>	20 300	20 300	20 <b>105.0</b> 300		100 <b>144.5</b> 1500		100 <b>147.2</b> 1500		20 <b>92.20</b> 300	20 300	20 300	
<b>min</b> <b>0°</b> <b>max</b>	50 300	50 300	50 <b>111.0</b> 300	75 <b>152.0</b> 600		100 <b>167.8</b> 1500		75 <b>160.6</b> 600	50 <b>102.8</b> 300	50 300	50 300	
<b>min</b> <b>4°</b> <b>max</b>	20 300	20 300	20 <b>86.49</b> 300		100 <b>136.8</b> 1500		100 <b>134.8</b> 1500		20 <b>84.03</b> 300	20 300	20 300	
<b>min</b> <b>6°</b> <b>max</b>				50 <b>85.50</b> 600		75 <b>103.70</b> 600		50 <b>93.80</b> 600				
<b>min</b> <b>8°</b> <b>max</b>					50 <b>70.00</b> 600		50 <b>78.46</b> 600					
	WIDE ANGLE EFFECT			NARROW ANGLE EFFECT						WIDE ANGLE EFFECT		

Validate this report with the security code «961YJHTJ» at: <https://extranet.idiada.com/hom-cve>  
 Verifique el informe con código de seguridad «961YJHTJ» en: <https://extranet.idiada.com/hom-cve>

CN21080122

IDIADA

\* LOS RESULTADOS PRESENTADOS SE REFIEREN ÚNICAMENTE A LA MUESTRA ENSAYADA.  
 THE PRESENTED RESULTS REFER ONLY TO THE TESTED SAMPLE.  
 \* QUEDA TERMINANTEMENTE PROHIBIDA LA REPRODUCCIÓN PARCIAL DE ESTE INFORME SIN PERMISO EXPRESO DE IDIADA.  
 THE PARTIAL REPRODUCTION OF THIS REPORT WITHOUT THE PERMISSION OF IDIADA IS COMPLETELY FORBIDDEN.  
 \* EL LABORATORIO HA CALCULADO LA INCERTIDUMBRE DE MEDIDA ASOCIADA A LOS RESULTADOS.  
 MEASUREMENT UNCERTAINTY OF THE RESULTS HAS BEEN CALCULATED BY THE LABORATORY.



Si dos o más sistemas ópticos están integrados en una luz especial de aviso / *If the optical systems are integrated in one special warning lamp:*

<p>Cada sistema óptico es conforme con las prescripciones fotométricas en el interior del ángulo horizontal que no está cubierto por uno de los otros sistemas ópticos. / <i>Each optical system fulfils the photometric requirements within the horizontal angle which is not covered by one of the other optical systems.</i></p>	<p><b>NO APLICABLE / NOT APPLICABLE</b></p>
<p>Todos los sistemas ópticos funcionan en fase. Nota: Sólo se aplica a cada mitad de la barra completa. / <i>All the optical systems work in phase. Note: This applies only to each half of a complete bar.</i></p>	<p><b>NO APLICABLE / NOT APPLICABLE</b></p>
<p>Una luz especial de aviso que está compuesta de más de una unidad separada, se acepta(n) la(s) disposición(es) geométrica(s) instalada(s) en el vehículo, si la distribución parcial de la luz de cada unidad simple separada se superpone con la distribución de luz parcial adyacente en el interior del campo angular horizontal de 360° y el campo angular vertical especificado para la categoría pertinente en una posición geométrica correspondiente a la distancia de 20 m, desde el vehículo en un plano vertical perpendicular al eje longitudinal del vehículo y localizado en la posición media entre las unidades de luces en un lado del vehículo. / <i>Special warning lamp device which is comprised of more than one separate unit, the geometrical arrangement(s) as installed at the vehicle is acceptable, if the partial light distribution of each single separate unit is overlapping with each adjacent partial light distribution inside a horizontal angular range of 360° and in a vertical angular range as specified for the relevant category in a geometrical position corresponding to a distance of 20 m, from the vehicle on a vertical plane that is perpendicular to the longitudinal axis of the vehicle and located midway between the lamp units on a side of the vehicle.</i></p>	<p><b>NO APLICABLE / NOT APPLICABLE</b></p>
<p>El vehículo dispone de un dispositivo capaz de detectar el fallo de una parte del sistema de la luz especial de aviso o la detección de fallo se realiza mediante un dispositivo previsto por el fabricante de la luz especial de aviso. / <i>Detection of the failure of a part of special warning system on the car or detection by the special warning lamp manufacturer.</i></p>	<p><b>NO APLICABLE / NOT APPLICABLE</b></p>

Validate this report with the security code «961YJHTJ» at: <https://extranet.idiada.com/hom-cve>  
Verifique el informe con código de seguridad «961YJHTJ» en: <https://extranet.idiada.com/hom-cve>

Lugar del ensayo / *Test place:* SQT Guangzhou, China

Fecha del ensayo / *Test date:* 09/08/2021



Joan Fonts Sala  
INGENIERO DE ENSAYOS  
*TEST ENGINEER*

- \* LOS RESULTADOS PRESENTADOS SE REFIEREN ÚNICAMENTE A LA MUESTRA ENSAYADA.  
*THE PRESENTED RESULTS REFER ONLY TO THE TESTED SAMPLE.*
- \* QUEDA TERMINANTEMENTE PROHIBIDA LA REPRODUCCIÓN PARCIAL DE ESTE INFORME SIN PERMISO EXPRESO DE IDIADA.  
*THE PARTIAL REPRODUCTION OF THIS REPORT WITHOUT THE PERMISSION OF IDIADA IS COMPLETELY FORBIDDEN.*
- \* EL LABORATORIO HA CALCULADO LA INCERTIDUMBRE DE MEDIDA ASOCIADA A LOS RESULTADOS.  
*MEASUREMENT UNCERTAINTY OF THE RESULTS HAS BEEN CALCULATED BY THE LABORATORY.*



DOCUMENTACIÓN TÉCNICA /  
*TECHNICAL DOCUMENTATION*

## INFORMATION FOLDER

FIRST APPLICATION DATE: 30/07/2021

### 1. Specification data

Type	BR0400622(B)	
Trade name or mark	BORY AUTO LIGHT	
Variants	--	
Function	Special Warning Lamp	
Applicable Regulation	ECE R. 65.00 Category XB2	
Flash Patterns	One pulse in one flash	
Color	Blue	
Number and category of Light sources	6xLEDs	
Rated	Voltage	12/24V
	Wattage	15W
Location of marking	Rated Voltage	Mark on the Housing
	Trade mark	Mark on the Housing
	Approval mark	Mark on the Housing
Number of separate units (if applicable)	--	
Only for Class II lamps: System used to obtain increased intensity at daytime	Two level of intensity (Class 2) in Blue Applying Yellow wire will activate the effective intensity "By day"	

### 2. Construction and material

Construction	Material	Remarks
Lens	PC	Clear
Housing	ADC12	Black
Electrical wiring	Copper covered with insulation	---

### 3. Name and address of manufacturer

Guangzhou Bory Auto Light Co., Ltd.

4/F, Building 8, No.2 Ke'er Road(Self compiled), Dongyong Town, Nansha District, Guangzhou, Guangdong 511443, China.

**NOTE:** APPROVAL MARKINGS ARE SHOWN IN THE ATTACHED DRAWINGS.  
THIS INFORMATION FOLDER CONSISTS OF 3 PAGES

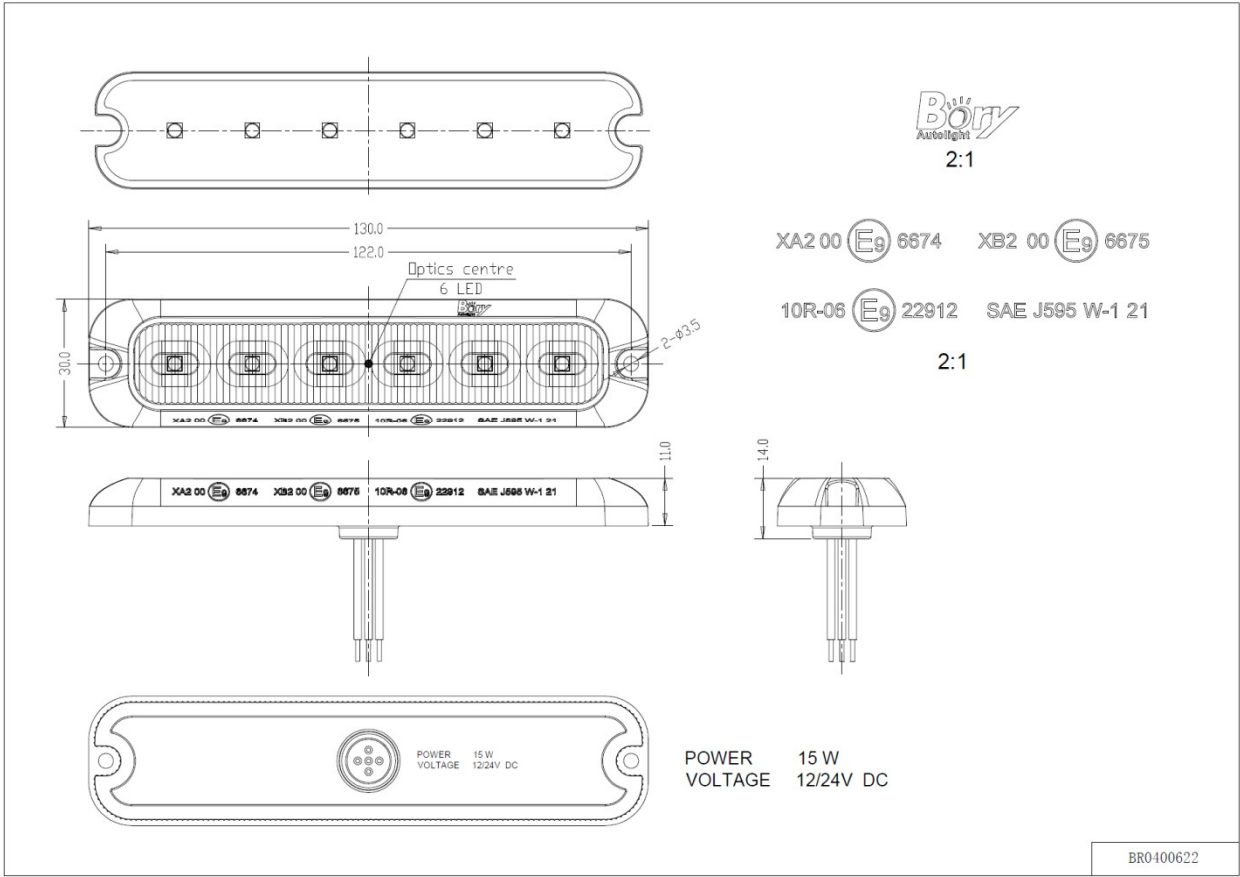

BR0400622

# CIRCUIT DIAGRAM

